

# **VALLIAMMAI ENGINEERING COLLEGE**

SRM NAGAR, KATTANKULATHUR – 603 203



## **PHYSICS PRACTICALS MANUAL**

### **GE6262: PHYSICS LABORATORY-II**

(Second semester B.E/B.Tech. students for the Academic Year 2016-2017)

Prepared by

Dr.H.Krishnan, Dr.M.Anbuechzhayan , Dr.K.Sarojini , Dr.K.Thiruppathi,  
Ms.S.Gandhimathi , Mrs.D.Praveena, Ms.R.Sasireka, Ms.R.NithyaBalaji & Ms.S.Sowmiya

Ms.M.P.Ramya Rajan

**Department of Physics**

(Private circulation only)

DEPARTMENT OF PHYSICS

**Instructions to the students**

The following instructions must be followed by the students in their laboratory classes.

1. Students are expected to be punctual to the lab classes. If they are late, they will be considered absent for that particular session.
2. Students should strictly maintain the dress code.
3. Students must bring their observation note, record note (completed with previous experiment) and the calculator to every lab class without fail.
4. Students are advised to come with full preparation for their lab sessions by
  - (i) Reading the detailed procedure of the experiment from the laboratory manual.
  - (ii) Completion of observation note book (i.e.) Aim, Apparatus required, Formula (with description), least count calculation, diagrams and the tabular column should be written in the observation note before entering into the laboratory.
5. Data entry in the observation note book must be by pen only.
6. Students must get attestations immediately for their observed readings.
7. Students should complete their calculations for their experiments and get it corrected on the same day of that experiment.
8. Students who miss observation, record note they have to do the experiment once again and get it corrected.
9. Class assessment marks for each experiment is based only on their performance in the laboratory.
10. Record note has to be completed then and there and get corrected when the students are coming for the next lab class.
11. Students must strictly maintain silence during lab classes.
12. If any of the students is absent for the lab class for genuine reasons, he/she will be permitted to do the experiment during the repetition class only.
13. Students are advised to perform their experiments under safety care.
14. If any student is found causing damage to the lab equipments, he/she shall replace the same with a new.

## CONTENTS

S. No	EXPERIMENTS	PAGE NO.
1	Determination of band gap of a semiconductor	1
2	Determination of coefficient of viscosity –poiseuille's method	5
3	Determination of Dispersive power of a prism-Spectrometer	11
4	Determination of thickness of a thin wire - Air wedge method	17
5	Determination of Rigidity modulus –Torsional pendulum	23
6	Determination of the Hall coefficient for given n-type and p-type semiconductor	31

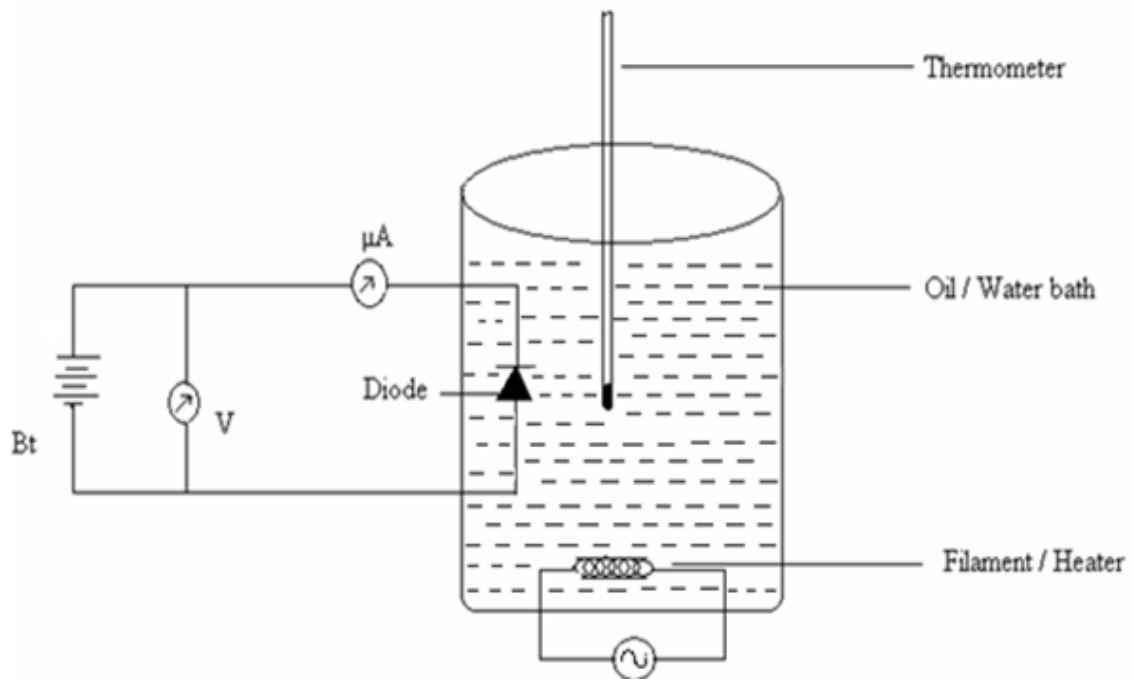

Fig 1.1. Circuit for band gap determination

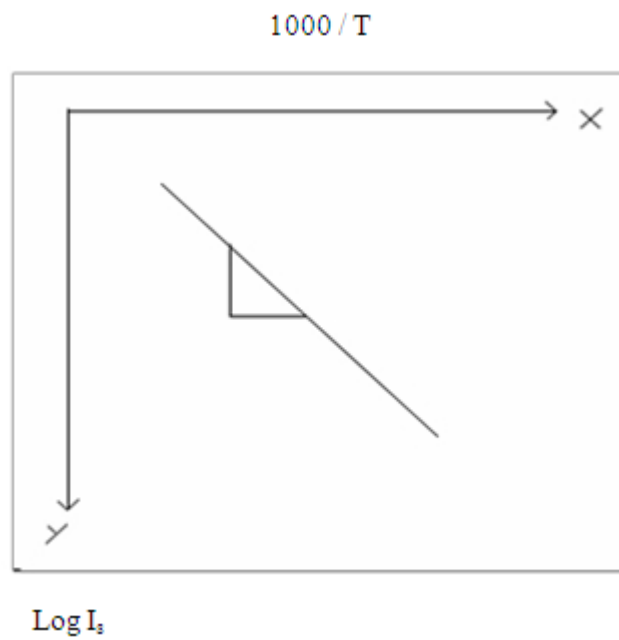

Fig1.2. Variation of current with inverse temperature in a reverse biased pn -diode

## 1. DETERMINATION OF BAND GAP OF A SEMICONDUCTOR

### AIM

To determine the band gap energy of a semiconductor by varying the temperature

### APPARATUS REQUIRED

Semiconductor diode, Heating arrangement to heat the diode, Ammeter, Voltmeter, thermometer.

### PRINCIPLE

For a semiconductor diode at 0K the valence band is completely filled and the conduction band is empty and it behaves as an insulator. If the temperature is increased, some of the valence electrons gains thermal energy greater than the forbidden energy ( $E_g$ ) and it moves to conduction band, which constitutes some current to flow through the semiconductor diode.

### FORMULA

$$\text{Band gap energy} \quad E_g = 0.198 \times \text{Slope} \quad \text{eV}$$

$$\text{Slope} = \log I_s / (1000/T)$$

Symbol	Explanation	Unit
$I_s$	Saturation current	$\mu\text{A}$
T	Absolute temperature	kelvin

### PROCEDURE

- The circuit is given as shown in Fig.(1.1)
- The semiconductor diode and the thermometer is immersed in the water or oil bath, in such a way that the thermometer is kept nearby the diode.
- The power supply is kept constant (2Volts).
- The heating mantle is switched ON and the oil bath is heated up to 70°C.
- Now the heating mantle is switched OFF and the oil bath is allowed to cool slowly.
- For every five degree fall of temperature the micro ammeter the reading  $I_s$  is noted.



S.No	Temperature	Temperature	1000 /T	I <sub>s</sub>	Log I <sub>s</sub>
unit	°C	K	K <sup>-1</sup>	x 10 <sup>-6</sup> A	
1					
2					
3					
4					
5					
6					
7					
8					
9					
10					

- A graph is plotted taking  $1000/T$  along x axis and  $\log I_s$  along negative y axis (Fig.1.2), (Since  $I_s$  in the order of micro-ampere,  $\log I_s$  value will come in negative).
- A straight line obtained as shown in model graph
- By finding the slope of the straight line, the band gap energy can be calculated using the given formula.

**CALCULATION**

$$E_g = 0.198 \times \text{Slope} \quad \text{eV}$$

$$E_g = 0.198 \times \log I_s / (1000/T) \quad \text{eV}$$

$$E_g = \dots\dots\dots \quad \text{eV}$$

**RESULT**

The band gap energy of the given diode is  $E_g = \dots\dots\dots$  eV.

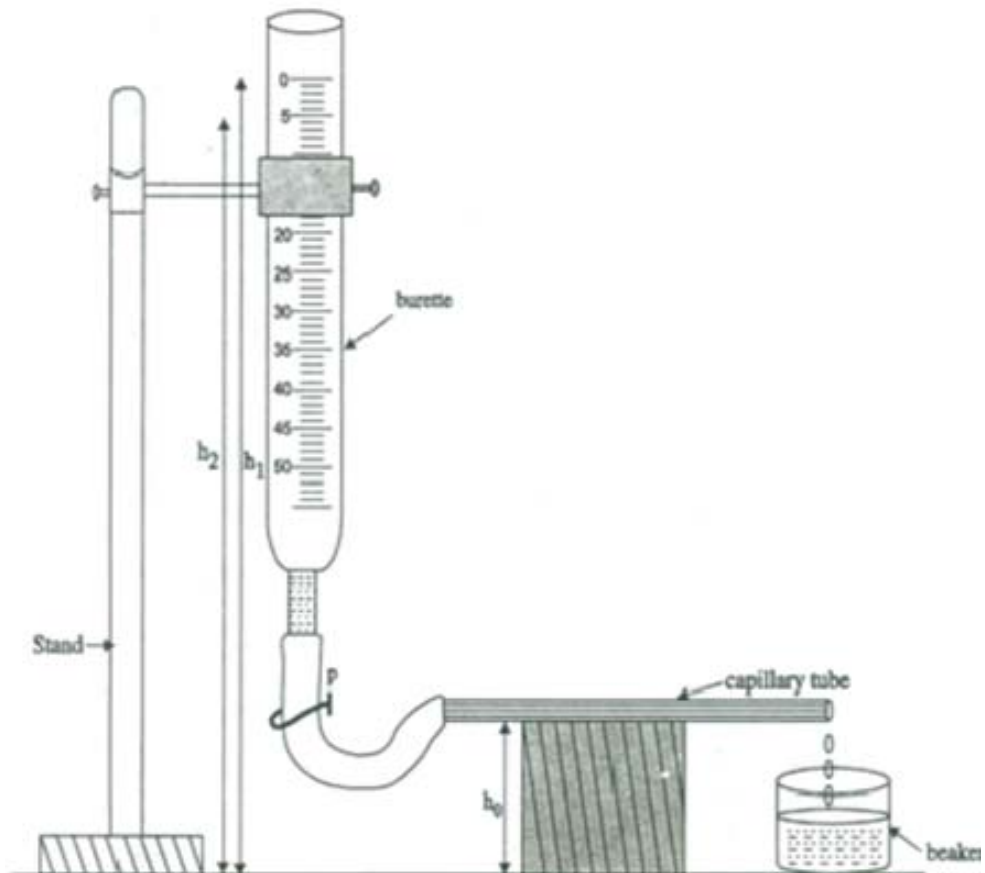

Fig 2.1. Viscosity of a liquid apparatus

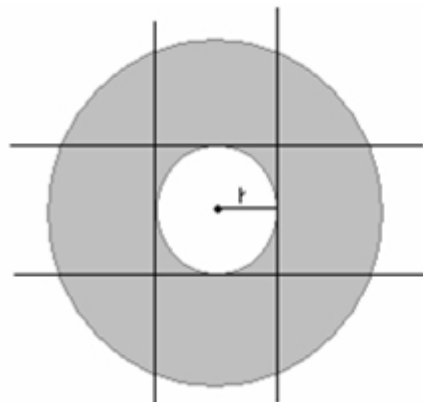

Fig.2.2. Radius of capillary tube



## 2. DETERMINATION OF COEFFICIENT OF VISCOSITY OF A LIQUID- POISEUILLE'S METHOD

### AIM

To determine the coefficient of viscosity of a given liquid by Poiseuille's method.

### APPARATUS REQUIRED

Graduated burette, Stop watch, Stand with clamp, Meter scale, Capillary tube, Rubber tube, Beaker, Pinch cock, Given liquid, Traveling microscope.

### PRINCIPLE

The liquid is allowed to flow through a uniform capillary tube which is held horizontally, under constant pressure difference between the two ends of the capillary. The flow of liquid through the tube is streamline and the layers which are in contact of the walls of the tube are at rest. The layer along the axis of the tube has the maximum velocity.

### FORMULA

The coefficient of viscosity of a liquid,

$$\eta = \frac{\pi \rho g r^4 (ht)}{8lV} \text{ Nsm}^{-2}$$

Symbol	Explanation	Unit
$\rho$	Density of the given liquid	$kg/m^3$
$g$	Acceleration due to gravity	$ms^{-2}$
$r$	Radius of the capillary tube	m
$h$	$\frac{h_1+h_2}{2} - h_0$ which is the pressure head	m
$h_1$	Height from the table to the initial level of liquid in burette	m
$h_2$	Height from the table to the final level of the liquid in burette.	m
$h_0$	Height from the table to the axis of the capillary tube	m
$l$	Length of the capillary tube	m
$V$	Volume of the liquid in 5cc	$m^3$

**Measurement for time for liquid flow**

$h_0 = \dots \times 10^{-2}$  meter       $\ell = \dots \times 10^{-2}$  meter

S.No.	Burette reading	Time while crossing the level	Range	Time for flow of 5 cc liquid $t$	Height of initial reading $h_1$	Height of Final reading $h_2$	Pressure head $h = \frac{h_1 + h_2}{2} - h_0$	$ht$
unit	cc	second	cc	second	cm	cm	cm	cm-sec
1.	0		0-5					
2.	5		5-10					
3.	10		10-15					
4.	15		15-20					
5.	20		20-25					
6.	25		25-30					
7.	30		30-35					
8.	35		35-40					
9.	40		40-45					
10.	45		45-50					
11.	50							
Mean height ( $ht$ ) = $\dots \times 10^{-2}$ m-sec								

**PROCEDURE**

- The dry burette is fixed on the stand using the clamps as shown in Fig.(2.1). The uniform circular bore capillary tube is fixed to the burette using a rubber tube.
- The capillary tube is arranged horizontal to the table. The stand is used to get uniform flow of a given liquid.
- A clamp and dry beaker is used to collect the water from the capillary tube for a known interval of time.
- The given liquid is poured into the burette. The stop clock is started when the liquid level crosses 0cc in burette.
- The time taken for the liquid to cross every 5cc (starts from 0cc) on the burette say 0, 5, 10, 15, 20, 25 ....50 cc are noted and tabulated.
- The time taken for 5 cc of the liquid is determined for the flow time  $t$  seconds from the table.
- The initial height  $h_1$  and final height  $h_2$  are noted for every 5 cc interval. The length of the capillary tube ( $l$ ) is measured by using meter scale.

**TO FIND THE RADIUS OF THE CAPILLARY TUBE**

- The radius of the capillary ( $r$ ) is determined using the traveling microscope. The capillary tube is fixed on the stand and traveling microscope is adjusted to view the inner circle of the capillary tube as shown in Fig. (2.2).
- The vertical cross wire of the telescope is adjusted to coincide with the left edge ( $V_1$ ) of the inner circle. The corresponding MSR and VSC are noted. Similarly, the cross wire adjusted with the right edge ( $V_2$ ) of the inner circle and the readings are noted.
- The experiment is repeated using the horizontal cross wire of the telescope and the corresponding readings  $H_1$  and  $H_2$  are tabulated.
- The inner diameter of the capillary tube is determined by finding the difference between  $V_1$  and  $V_2$ ,  $H_1$  and  $H_2$ . The average value of the diameter is used for the calculation



**DETERMINATION OF LEAST COUNT OF TRAVELLING MICROSCOPE**

Least count = 1 MSD – 1 VSD

$$20 \text{ MSD} = 1 \text{ cm}$$

$$\text{Value of 1 MSD} = \frac{1}{20} \text{ cm} = 0.05 \text{ cm}$$

Number of Vernier Scale Division = 50

$$50 \text{ VSD} = 49 \text{ MSD}$$

$$1 \text{ VSD} = \frac{49}{50} \text{ MSD} = \frac{49}{50} \times 0.05 = 0.049$$

$$\text{LC} = 0.05 - 0.049 = 0.001 \text{ cm}$$

$$\text{LC} = 0.001 \text{ cm}$$

**To find the radius of the capillary tube(r)**

Horizontal cross wire				Vertical cross wire			
Position	MSR cm	VSC div	MSR + (VSC X LC) cm	Position	MSR cm	VSC div	MSR + ( VSC X LC) cm
Top 				Left 			
Bottom 				Right 			

Difference (d<sub>1</sub>) = ..... cm

Difference (d<sub>2</sub>) = ..... cm

**CALCULATION**

Density of the given liquid  $\rho = 1000 \text{ kg/m}^3$

Acceleration due to gravity  $g = 9.8 \text{ m/s}^2$

Radius of the capillary tube  $r = \dots\dots\dots \text{ m}$

Length of the capillary tube  $l = \dots\dots\dots \text{ m}$

The product of 'ht' =  $\dots\dots\dots \text{ ms}$

Volume of liquid collected  $V = \dots\dots\dots \text{ m}^3$

The coefficient of viscosity of a liquid,

$$\eta = \frac{\pi \rho g r^4 h t}{8 l V} \text{ Nsm}^{-2}$$

**RESULT**

The coefficient of viscosity of a liquid  $\eta = \dots\dots\dots \text{ Nsm}^{-2}$

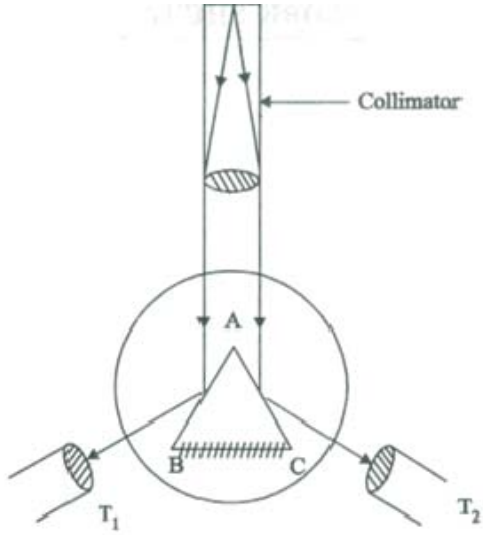

Fig . 3.1. Angle of the prism

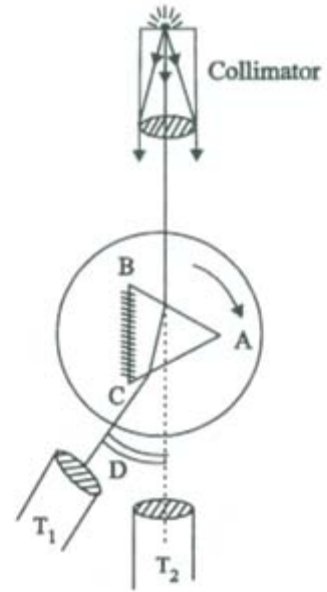

Fig.3.2.Angle of minimum deviation

**To find the Angle of the prism (A) – Spectroscopic reading**

Reflected reading	Vernier A			Vernier B		
	MSR	VSC	Total reading	MSR	VSC	Total Reading
unit	deg	div	deg	deg	div	deg
Reading of the image reflected from one face (left)			R <sub>1</sub>			R <sub>1</sub>
Reading of the image reflected from other face (right)			R <sub>2</sub>			R <sub>2</sub>
	2A(left) = (R <sub>1</sub> ~R <sub>2</sub> ) =			2A(right) = (R <sub>1</sub> ~R <sub>2</sub> ) =		
Mean $A = \frac{(2A (left) + 2A (right))}{4} =$						

### 3. DETERMINATION OF DISPERSIVE POWER OF A PRISM - SPECTROMETER

#### AIM

To determine the refractive index of the prism and Dispersive power of the prism using Spectrometer.

#### APPARATUS REQUIRED

Spectrometer, Glass prism, Sodium vapour lamp, Spirit level, Reading lens

#### PRINCIPLE

Refraction through th prism. By snell's law of refraction (refractive index of second medium with respect of first medium  $\mu = \sin i / \sin r$  ,where i = angle of incidence and r = angle of refraction and when the prism is placed in a minimum deviation position ,the incident and the emergent rays are symmetrical with respect to the faces of the prism andt hat refracted ray through the prism is parallel to its base.

#### FORMULA

Refractive index of the given prism,

$$\mu = \frac{\sin \left( \frac{A+D}{2} \right)}{\sin \left( \frac{A}{2} \right)} \text{ No unit}$$

Dispersive power of prism,

$$\omega = \left\{ \frac{\mu_v - \mu_r}{\mu_y - 1} \right\} \text{ No unit}$$

Symbol	Explanation	unit
A	The angle of prism	Degree
D	The angle of minimum deviation	Degree
$\mu_v$	Refractive index of the prism for violet colour	No unit
$\mu_r$	Refractive index of the prism for red colour	No unit
$\mu_y$	Refractive index of the prism for yellow colour	No unit

**To find the angle of minimum deviation (D) - Spectroscopic reading**

Total Reading = MSR+ (VSC X LC)

LC = 1'

S.No	Refracted Ray Readings	Vernier A			Vernier B			Angle of minimum deviation D		Mean
		MSR	VSC	TR	MSR	VSC	TR	Ver A $R_1 \sim R_2$	Ver B $R_1 \sim R_2$	
	Line of the spectrum	deg	div	deg	deg	div	deg	deg	deg	
	Unit									$D = \frac{(ver A + ver B)}{2}$
1.	Violet			$R_1$			$R_1$			
2.	Yellow			$R_1$			$R_1$			
3.	Red			$R_1$			$R_1$			
4.	Direct Ray			$R_2$			$R_2$			



## PROCEDURE

### (i) CALCULATION OF ANGLE OF PRISM

- The initial adjustments of the spectrometer are made. The slit is illuminated by mercury vapour lamp. The given prism is mounted on prism table such that the light emerging from the collimator should be made to incident on both the faces of the prism as shown in Fig.(3.1).
- The telescope is rotated to one side (left) and get the reflected image from the face(left) is made to coincide with the vertical cross wire. The main scale and vernier coincidence are noted on Vernier-A and Vernier-B.
- Similarly, readings are taken for the image reflected by the other face (right) of the prism. The difference between the two reading are given the twice the angle of prism. From that angle of prism (A) is calculated.

### (ii) CALCULATION OF ANGLE OF MINIMUM DEVIATION (D) AND REFRACTIVE INDEX ( $\mu$ )

- The prism is mounted such that the incident light fall on one of the refractive face of the prism.
- The telescope is rotated to catch the refracted image of anyone of the colour which emerges from other refracting face of the prism.
- Now by viewing through the telescope the prism table is slightly rotated in such a way that the violet image moves towards the direct ray and at a particular position it retraces its original path. This position is called Minimum Deviation Position.
- The prism table is fixed and hence now all the colours in the prism are said to be into minimum deviation position as shown in Fig. (3.2). The tangential screw is adjusted to coincide with the image of each and every colour with the vertical crosswire and the readings are tabulated.
- The prism is removed and the direct ray reading is noted. The difference between the direct ray and the refracted ray readings for each colour gives the angle of minimum deviation (D) for that respective colour.
- Then by substituting the values of 'D' and 'A' in the equation 1, the refractive indices ( $\mu$ ) for each and every colour can be calculated.

### (iii) CALCULATION OF DISPERSION POWER

- Finally by choosing any two colour with refractive indices as  $\mu_y$ ,  $\mu_v$ , and  $\mu_r$  the dispersive power of the prism is calculated using the equation.
- Similarly, for various values of  $\mu_y$ ,  $\mu_v$ , and  $\mu_r$  the dispersive powers are calculated and the mean of all the dispersive power is calculated.



### DETERMINATION OF LEAST COUNT

$$2\text{MSD} = 1^\circ$$

$$1\text{MSD} = 1^\circ/2 = 0.5^\circ = 30'$$

$$\text{LC} = 1 \text{ MSD} - 1 \text{ VSD}$$

Number of divisions in vernier scale = 30

$$30 \text{ VSD} = 29 \text{ MSD}$$

$$1 \text{ VSD} = 29/30 \times \text{MSD} = 29/30' \times 30' = 29'$$

$$\text{LC} = 30' - 29'$$

$$\text{LC} = 1' \text{ (One minute)}$$

### CALCULATION

Angle of prism  $A = \dots\dots\dots$  degree.

Refractive index of the prism  $\mu_v = \dots\dots\dots$  no unit.

Refractive index of the prism  $\mu_r = \dots\dots\dots$  no unit.

Refractive index of the prism  $\mu_y = \dots\dots\dots$  no unit.

i) Refractive index of the given prism,

$$\mu_v = \frac{\sin\left(\frac{A+D}{2}\right)}{\sin\left(\frac{A}{2}\right)} \text{ No unit}$$

Refractive index of the given prism =  $\mu_v = \dots\dots\dots$  No unit.

ii) Dispersive power of the prism

$$\omega = \left\{ \frac{\mu_v - \mu_r}{\mu_y - 1} \right\} \quad \text{No unit}$$

Dispersive power of the prism  $\omega = \dots\dots\dots$  No unit.

**RESULT**

Angle of prism  $A = \dots\dots\dots$  degree

Dispersive power of the prism  $\omega = \dots\dots\dots$  no unit

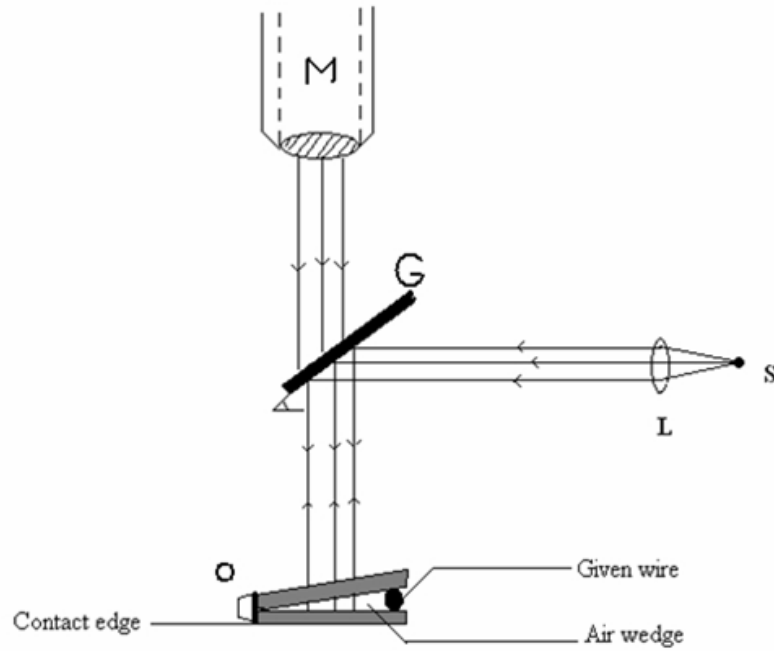

Fig.3.1.Air-wedge arrangement

To find the fringe width ( $\beta$ )

Order of the band	Microscopic reading			Width of 5 bands $5\beta$
	MSR	VSC	TR = MSR + (VSC x LC)	
Unit	cm	div	cm	
n				
n+5				
n+10				
n+15				
n+20				
n+25				
n+30				
n+35				
n+40				
n+45				
n+50				

Mean =  $5\beta = \dots\dots\dots \times 10^{-2}$  meter

Mean width of one band  $\beta = 5\beta/5 = \dots\dots\dots \times 10^{-2}$  meter.

#### 4. DETERMINATION OF THICKNESS OF A THIN WIRE - AIR WEDGE METHOD

##### AIM

To determine the thickness of the thin wire by forming the interference fringes using the air wedge set up.

##### APPARATUS

Traveling microscope, Sodium vapour lamp, Optically plane rectangular glass plates, Thin wire, Reading lens, Condensing lens with stand, Rubber band, Wooden box with glass plate inclined at  $45^{\circ}$ .

##### PRINCIPLE

A wedge shaped air film is formed when a thin wire is introduced between two optically plane glass plates. When a parallel beam of monochromatic light is incident normally on this arrangement, interference occurs between the two rays; one is reflected from the front surfaces and the other at the back. These two reflected rays produce a pattern of alternate dark and bright interference fringes.

##### FORMULA

Thickness of the thin wire,

$$t = \frac{\lambda l}{2\beta} \text{ meter}$$

Symbol	Explanation	unit
$l$	Distance between the edge of contact and the wire	m
$\lambda$	Wavelength of sodium light	m
$\beta$	Mean fringe width	m

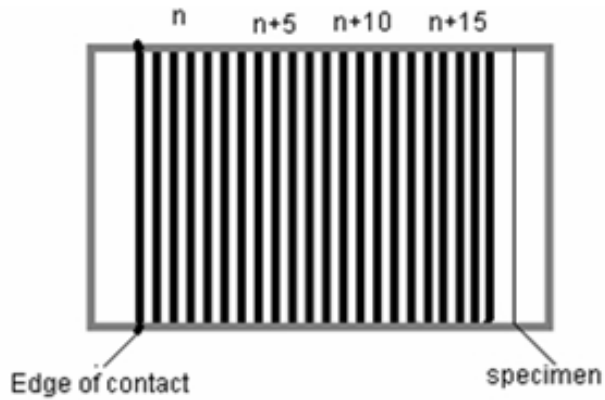

Fig.3.2. Interference –Fringe pattern

**DETERMINATION OF LEAST COUNT**

Least count = 1 MSD – 1 VSD

$$20 \text{ MSD} = 1 \text{ cm}$$

$$\text{Value of 1 MSD} = \frac{1}{20} \text{ cm} = 0.05 \text{ cm}$$

Number of Vernier Scale Division = 50

$$50 \text{ VSD} = 49 \text{ MSD}$$

$$1 \text{ VSD} = \frac{49}{50} \text{ MSD} = \frac{49}{50} \times 0.05 = 0.049$$

$$\text{LC} = 0.05 - 0.049 = 0.001 \text{ cm}$$

$$\text{LC} = 0.001 \text{ cm}$$

**To determine the distance between edge of contact and specimen wire ( $\ell$ )**

position	MSR	VSC	TR = MSR + (VSC x LC)
	cm	div	cm
Edge of contact (rubber band)			R <sub>1</sub>
Specimen wire			R <sub>2</sub>

$$\ell = R_1 - R_2 = \dots\dots\dots \times 10^{-2} \text{m.}$$

## PROCEDURE

- Two optically plane glass plates are placed one over the other and tied together by means of a rubber band at one end.
- The given thin wire is introduced in between the two glass plates, so that an air wedge is formed between the plates as shown in fig.(3.2 ) this set up is placed on the horizontal plate of the traveling microscope.
- The sodium vapour lamp is used as a source and the beam is made parallel by means of a condensing lens. The parallel beam of light is incident on a plane glass plate inclined at an angle of  $45^{\circ}$  and gets reflected.
- The reflected light is incident normally on the glass plate in contact. Interference takes place between the light reflected from the top and bottom surfaces of the glass plate and is viewed through the traveling microscope. Therefore, the number of equally spaced dark and bright fringes are formed which are parallel to the edge of contact.
- For the calculation of the single fringe width the microscope is adjusted so that the bright or dark fringe near the edge of contact is made to coincide with the vertical cross wire and this is taken as the  $n^{\text{th}}$  fringe. The reading from the horizontal scale of the traveling microscope is noted.
- The microscope is moved across the fringes using the horizontal transverse screw and the readings are taken when the vertical cross wire coincides with every successive 5 fringes. The mean of this gives the fringe width ( $\beta$ ).

### **To find the distance between the rubber band and specimen wire**

- The cross wire is fixed at the inner edge of the rubber band and the readings from the microscope is noted. Similarly reading from the microscope is noted keeping the cross wire at the specimen wire. The difference between these two values gives the value of  $\ell$ . Substituting the value  $\beta$  and  $l$  in the equation then the thickness of the given thin wire can be determined.



**CALCULATION**

1. Distance between the edge of contact and the wire ( $\ell$ ) = .....m
2. Wavelength of sodium light( $\lambda$ ) = .....m
3. Mean fringe width( $\beta$ ) = .....m

Thickness of the thin wire,

$$t = \frac{\lambda \ell}{2\beta} \text{ meter}$$

Thickness of the thin wire (t) = .....m

**RESULT**

Thickness of the thin wire (t) = ..... x  $10^{-6}$  m.





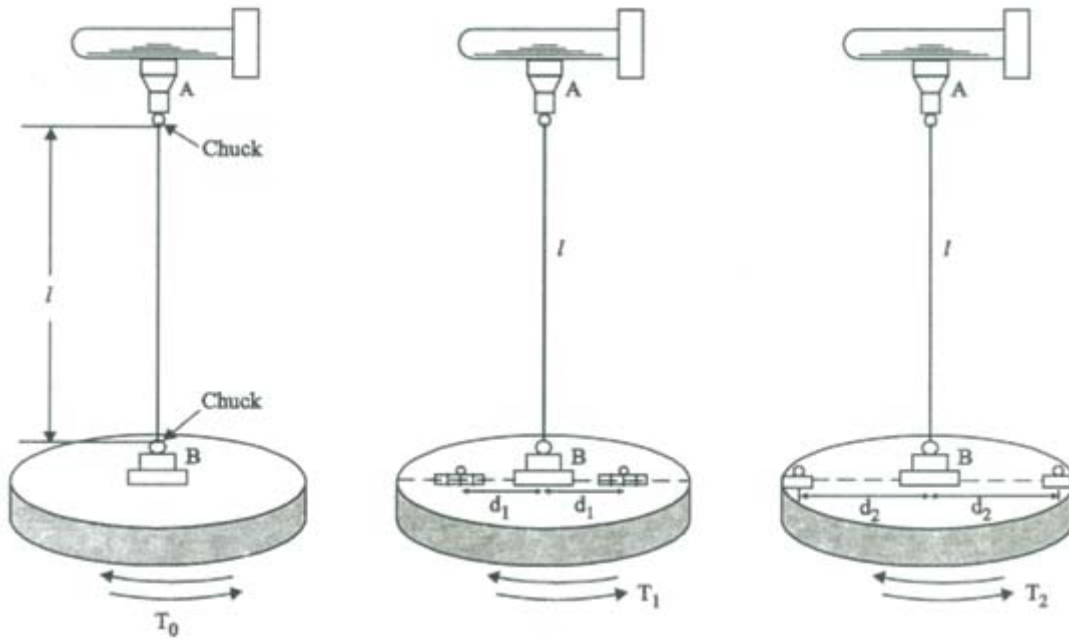

Fig.5.1. Torsional Pendulum

**To find the time period of oscillations**

Length of suspension wire  $l = \dots\dots\dots$ cm

Position of equal masses	Time for 10 oscillations			Time period
	Trial 1	Trail 2	Mean	
Unit	second	second	second	second
Without masses				$T_0 =$
Masses at closest distance. $d_1 = \dots\dots\dots \times 10^{-2}$ m				$T_1 =$
Masses at maximum distance. $d_2 = \dots\dots\dots \times 10^{-2}$ m				$T_2 =$

## 5. DETERMINATION OF RIGIDITY MODULUS –TORSIONAL PENDULUM

### AIM

To determine the moment of inertia of a given disc by Torsional oscillations and The rigidity modulus of the material of the suspension wire.

### APPARATUS

Torsional pendulum, Stop clock, Meter scale, Two symmetrical mass, Screw gauge.

### PRINCIPLE

The suspension wire is twisted by the circular disc fixed at the bottom of the wire and the wire undergoes shearing strain which leads to torsional oscillations. The angular acceleration of the disc is proportional to its angular displacement and is always directed towards its mean position and the motion of the disc is simple harmonic.

### FORMULA

Moment of inertia of the circular disc,

$$I = \frac{2m(d_2^2 - d_1^2)T_0^2}{T_2^2 - T_1^2} \text{ kg.m}^2$$

Rigidity modulus of the wire,

$$\eta = \frac{8\pi l l}{T_0^2 r^4} \text{ N/ m}^2$$



**LEAST COUNT OF THE SCREW GAUGE:**

$$\text{Pitch} = \frac{\text{Distance moved by the head scale on the pitch scale.}}{\text{Number of rotations given to the head scale.}}$$

$$\text{Least count (LC)} = \frac{\text{Pitch}}{\text{Total number of divisions on the head scale}}$$

Pitch = 5 mm/ 5 = 1 mm  
 LC = 1 mm/ 100 = 0.01 mm.

**To find the radius (r) of the specimen using screw gauge**

LC = 0.01 mm

Z.E = .....div

Z.C = .....mm

S. No.	PSR	HSC	HSR= HSC x LC	Observed Reading = PSR + HSR	Correct Reading = OR + ZC
Unit	mm	div	mm	mm	mm

Mean (d) =----- x 10<sup>-3</sup> m

Radius of the specimen wire (r) = d/2 = ..... x 10<sup>-3</sup> m

Symbol	Explanation	unit
m	mass of one cylinder placed on the disc(100 gm)	kg
$d_1$	Closest distance ( minimum) between suspension wire and the centre of mass of the cylinder	m
$d_2$	Farthest distance ( maximum) between suspension wire and the centre of mass of the cylinder	m
$T_0$	Period of oscillation without any mass on the disc	s
$T_1$	Period of oscillation when equal masses are placed on the disc at a distance $d_1$	s
$T_2$	Period of oscillation when equal masses are placed on the disc at a distance $d_2$	s
$\ell$	length of the suspension wire	m
r	Radius of the wire	m

### PROCEDURE

- When the suspension wire is twisted by the circular disc fixed at the bottom of the wire, the wire undergoes shearing strain. This is called torsion. Because of this torsion, the disc executes oscillation called torsional oscillation.
- The Torsional pendulum consists of a circular disc suspended by a thin suspended wire, as shown in Fig. (5.1), whose rigidity modulus is to be noted. The top end of the wire is fixed by a chuck. The circular disc is attached to the other end of the wire.

### Calculation of $T_0$

- Adjust the wire so that its length is fixed value say 50 cm. Make a vertical

chalk mark on the disc when it is rest as a reference. By making a small twist to the circular disc, set up Torsional oscillations. After the first few oscillations, just as the mark on the disc passes the equilibrium positions, a stop clock is started. The time taken for 10 complete oscillations is noted. The experiments are repeated for second trial and mean value is calculated. The mean value of the period is noted as  $T_0$ .

### Calculation of $T_1$

- The two identical cylindrical masses are placed at equal distance on either side of the central chuck as close as possible. The distance  $d_1$  is measured between the wire and the centre of the cylindrical mass. By twisting the disc, the time taken for 10 complete oscillations is noted. The mean value of the time period is noted as  $T_1$ .

### Calculation of $T_2$

- The identical masses are arranged symmetrically as far away from the axis of the rotation as possible. The distance  $d_2$  is measured between the centre of the cylindrical mass of the time taken for 10 complete oscillations is calculated in the same manner as that of the calculation of  $T_0$  and  $T_1$ .

### Calculation of Moment Of Inertia and Rigidity Modulus

- The mean value of the radius and length of the wire is measured accurately by a screw gauge and meter scale respectively. The moment of the inertia of the circular disc and the rigidity modulus of the suspension wire are calculated by substituting the values in the equations respectively.
- Moment of Inertia can also be determined theoretically  $I = MR^2$ , where  $M$ = Mass of the Disc,  $R$ = radius of the Disc.

### CALCULATION

Mean radius of the wire  $r = \dots\dots\dots$  m

Length of the wire  $\ell = \dots\dots\dots$  m

Mass of the identical cylinder  $m = \dots\dots\dots$  kg

Closest distance between suspension wire & the centre of symmetrical mass  $d_1 = \dots\dots\dots$  m

Farthest distance between suspension wire& the centre of symmetrical mass  $d_2 = \dots\dots\dots$  m

Period of oscillations (without masses)  $T_0 = \dots\dots\dots$  sec

Period of oscillations with masses at 'd<sub>1</sub>' distance  $T_1 = \dots\dots\dots$  sec

Period of oscillations with masses at 'd<sub>2</sub>' distance  $T_2 = \dots\dots\dots$  sec

The moment of inertia of the circular disc,

$$I = \frac{2m(d_2^2 - d_1^2)T_0^2}{T_2^2 - T_1^2} \text{ kg.m}^2$$

$$I = \dots\dots\dots \text{ kg/m}^2$$

Rigidity modulus of them wire,

$$\eta = \frac{8\pi l l}{T_0^2 r^4} \text{ N/ m}^2$$

$$\eta = \dots\dots\dots \text{ N/m}^2$$

**RESULT**



(i) Moment of inertia of the circular disc  $I =$  \_\_\_\_\_  $\text{kg m}^2$

(ii) Rigidity modulus of the given wire  $\eta =$  \_\_\_\_\_  $\text{Nm}^{-2}$





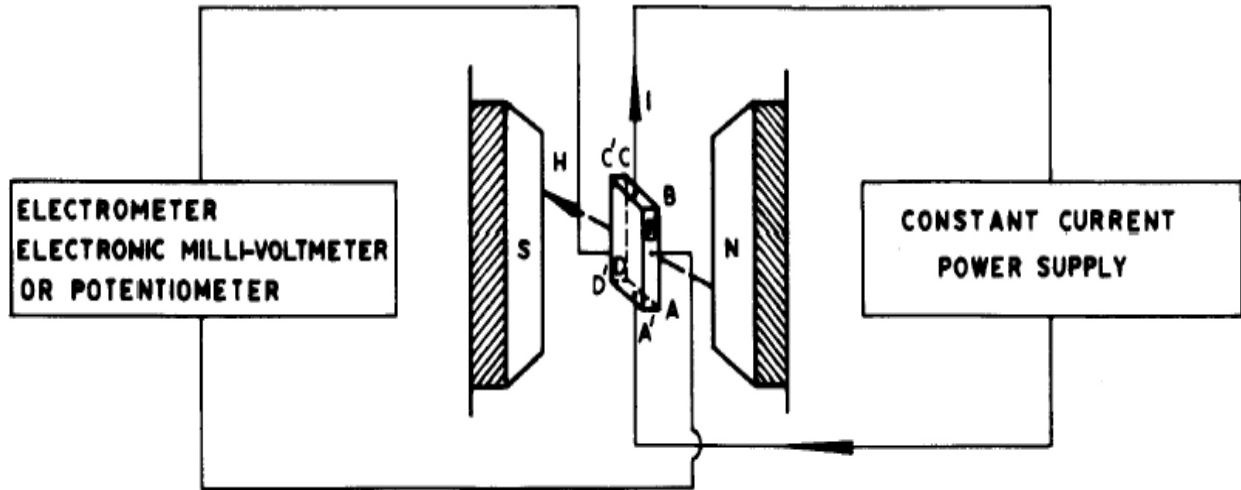

Fig.6.1.Hall apparatus set up

Determination of Hall Coefficient n-type material

S.No	Hall current I	Constant current A	Magnetic field H gauss	Hall Voltage $V_{Hh}$	Hall Coefficient $R_H$
	mA			mV	
1					
2					

## 6. Determination of the Hall coefficient for given n-type and p-type semiconductor

### Aim

To determine the Hall coefficient of the given n type or p-type semiconductor

### Apparatus Required

Hall probe (n type or p type), Hall Effect setup, Electromagnet, constant current power supply, gauss meter etc.

### Principle

Hall effect: When a current carrying conductor is placed in a transverse magnetic field, a potential difference is developed across the conductor in a direction perpendicular to both the current and the magnetic field.

### Formulae

i) Hall coefficient  $R_H = \frac{v \times t}{I \times H} \times 10^{-4} \text{ cm}^3 \text{ C}^{-1}$

ii) Carrier density  $n = \frac{1}{R_H \times q} \text{ cm}^{-3}$

iii) Carrier mobility  $m = R_H \times s \text{ cm}^2 \text{ V}^{-1} \text{ s}^{-1}$



Determination of Hall Coefficient p-type material

S.No	Hall current I	Constant current	Magnetic field H	Hall Voltage $V_{Hh}$	Hall Coefficient $R_H$
	mA	A	gauss	mV	
1					
2					

Symbol	Explanation	Unit
$V_H$	Hall voltage	volt
$t$	Thickness of the sample	cm
$I$	Current	ampere
$H$	Magnetic field	Gauss
$n$	Carrier density	$\text{cm}^{-3}$
$q$	Charge of the electron or hole	C
$m$	Carrier mobility	$\text{cm}^2\text{V}^{-1}\text{s}^{-1}$
$R_H$	Hall coefficient	$\text{cm}^3\text{C}^{-1}$
$s$	Conductivity	$\text{C V}^{-1}\text{s}^{-1}\text{m}^2$

## Procedure

- Connect the widthwise contacts of the hall probe to the terminals marked as ‘voltage’ (i.e. potential difference should be measured along the width) and lengthwise contacts to the terminals marked (i.e. current should be measured along the length) as shown in fig.6.1
- Switch on the Hall Effect setup and adjust the current say 0.2 mA.
- Switch over the display in the Hall Effect setup to the voltage side.
- Now place the probe in the magnetic field as shown in fig and switch on the electromagnetic power supply and adjust the current to any desired value. Rotate the Hall probe until it become perpendicular to magnetic field. Hall voltage will be maximum in this adjustment.
- Measure the Hall voltage and tabulate the readings.
- Measure the Hall voltage for different magnetic fields and tabulate the readings.
- Measure the magnetic field using Gauss meter
- From the data, calculate the Hall coefficient, carrier mobility and current density.



### Observations and Calculations

(1) Thickness of the sample =  $t =$  \_\_\_\_\_ cm

(2) Resistivity of the sample =  $r =$  \_\_\_\_\_  $\text{V C}^{-1} \text{s cm}$

(3) Conductivity of the sample =  $s =$  \_\_\_\_\_  $\text{CV}^{-1} \text{s}^{-1} \text{cm}^{-1}$

(4) The hall coefficient of the sample =  $R_H =$  \_\_\_\_\_  $\times 10^8$   
= \_\_\_\_\_

(5) The carrier density of the sample =  $n = \frac{1}{R_H \times q} =$  \_\_\_\_\_

(6) The carrier mobility of the sample =  $R_{HS}$

**Result**

1. The Hall coefficient of the given semi conducting material =
2. The carrier density =
3. The carrier mobility =



## DATA OF PHYSICAL CONSTANTS & STANDARD VALUES

S.No.	Physical Constants	Symbol	Value in SI Unit
1	Velocity of light	C	$3 \times 10^8$ m/s
2	Acceleration due to gravity	g	$9.8$ m/s <sup>2</sup>
3	Planck's constant	h	$6.625 \times 10^{-34}$ Js
4	Charge of an electron	e	$1.6 \times 10^{-19}$ C
5	Avogadro number	N <sub>A</sub>	$6.023 \times 10^{26}$ atoms/ k mole
6	Boltzmann constant	k	$1.3 \times 10^{-23}$ J/K
7	Rigidity modulus of steel (cast)	n	7.4 - 7.6
8	Rigidity modulus of steel (mild)	n	8.9
9	Viscosity of water	η	$8.1 \times 10^{-4}$ Nsm <sup>-2</sup>
10	Viscosity of kerosene	η	0.0020 Nsm <sup>-2</sup>
11	Thickness of a thin wire	t	$3 \times 10^{-5}$ m
12	Band gap(germanium)	E <sub>g</sub>	0.67 eV
13	Band gap(Silicon)	E <sub>g</sub>	1.1 eV
14	Dispersive power of the prism( Crown)	ω	0.015
15	Dispersive power of the prism( Dense Crown)	ω	0.018



## **VIVA QUESTIONS & ANSWERS**

### **1. BAND GAP OF A SEMICONDUCTOR**

#### **1. Define Fermi level**

Fermi level is that state at which the probability of electron occupation is  $\frac{1}{2}$  at any temperature above 0K and also it is the level of maximum energy of the filled states at 0K.

#### **2. What are intrinsic and extrinsic semiconductors?**

Intrinsic semiconductors are semiconductors in pure form. A semiconducting material in which charge carriers originate from impurity atoms added to the material is called extrinsic semiconductor.

### **2. COEFFICIENT OF VISCOSITY OF A LIQUID**

#### **1. Define viscosity and coefficient of viscosity.**

In the presence of a relative motion between two layers of a liquid, an opposing tangential force sets in between the layers to destroy the relative motion. This property of the liquid is termed viscosity and is analogous to friction, the tangential force acting per unit area over two adjacent layers of the liquid for a unit velocity gradient is referred to as the coefficient of viscosity.

#### **2. How does the coefficient of viscosity change with temperature?**

The coefficient of viscosity decreases with rise in temperature in the case of liquids, but for gases it increases with rise in temperature.

#### **3. Can you use this method for all types of liquids?**

No, this method can be suitably applied for liquids of low viscosity. For highly viscous liquids, Stokes's method can be used.

### **3.DISPERSIVE POWER OF PRISM**

#### **1. Define refractive index**

The ratio of the sine of the angle of incidence to the sine angle of refraction is constant for any two media, i.e.,  $\sin i / \sin r = \mu$  a constant known as refractive index.

#### **2. How does refractive index change with wave length of light ?**

Higher the wavelength, smaller is the refractive index.

#### **3. Define the dispersive power of the prism**

Dispersive power indicates the ability of the material of the prism to disperse the light rays. It is defined as the ratio of the angular dispersion to the deviation of the mean ray.

### **4. AIR WEDGE**

#### **1. What do you mean by interference of light ?**

When two waves superimpose over each other, resultant intensity is modified. The modification in the distribution of intensity in the region of superposition is called interference.

#### **2. What type of source is required in division of amplitude?**

In division of amplitude a broad source is required so that the whole film may be viewed together.

#### **3. What is the shape of the fringes in wedge shaped film?**

The fringes in wedge shaped film are straight line fringes.

### **5.RIGIDITY MODULUS- TORSIONAL PENDULUM**

#### **1. What is torsional pendulum?**

A body suspended from a rigid support by means of a long and thin elastic wire is called torsional pendulum.

#### **2. What is the type of oscillation?**

This is of simple harmonic oscillation type.

#### **7. How will you determine the rigidity of fluids?**

As fluids do not have a shape of their own, hence they do not possess rigidity. Hence there is no question of determining it.

**ANNA UNIVERSITY: CHENNAI – 600 025**

**B.E./B.Tech. DEGREE EXAMINATIONS, MAY/JUNE - 2013**

**Regulations - 2008**

**Second Semester**

**Date:**

**(Common to All Branches)**

**GS2165 – PHYSICS LABORATORY**

**Time: 2 Hours**

**Maximum Marks: 50**

1. Ensure streamlined flow of the given liquid through the capillary tube and determine the coefficient of viscosity of the same using Poiseuille's method ( $\rho = 1000 \text{ kg/m}^3$  &  $g = 9.8 \text{ m/s}^2$ )
2. Find the depression at the mid point of the given wooden beam for 50 gm, 100 gm, 150 gm, 200 gm and 250 gm. Determine the Young's Modulus of the material of the given bar using non-uniform bending method and hence find the mass of the given object.
3. Determine (i) the wavelength of the given laser light and (ii) the angle of divergence.
4. Determine (i) the average size of the particles of a given powder using laser light of  $\lambda = 650 \text{ nm}$  and (ii) the Numerical Aperture of the given optical fiber.
5. Determine the coefficient of thermal conductivity of a bad conductor using Lee's disc apparatus. Specific heat of the material of the given disc =  $370 \text{ Jkg}^{-1}\text{K}^{-1}$
6. Determine the band gap energy of the given semiconductor using diode apparatus.
7. Determine (i) the velocity of ultrasonic waves in the given liquid and (ii) the compressibility of the given liquid using ultrasonic interferometer.
8. Determine (i) the period of oscillation of a given Torsional pendulum for a fixed length and (ii) the moment of inertia of the disc and rigidity modulus of the wire. Compare them with the theoretical values.
9. Determine the refractive index of the material of the prism for blue, green, yellow 1 & 2 and extreme red, and calculate the dispersive power of the same for blue & red, blue & green and yellow 1 & 2.
10. Form interference fringes with the help of two optically plane glass plates, wire and sodium vapour lamp ( $\lambda = 589.3 \text{ nm}$ ). Record the readings for at least four sets of fringes difference. Determine the width of one fringe and hence calculate the thickness of the given wire.



11. Assuming the wavelength of Green as  $\lambda = 546.1\text{nm}$ , standardize the given grating i.e find the number of lines per meter in the grating and then determine the wavelength of the prominent spectral lines of mercury spectrum. (First Order Violet, Blue, Yellow – I, Yellow – II, Extreme Red).
12. Determine (i) the wavelength of the laser light using grating ( $N= 100$  lines/mm) and (ii) the Numerical Aperture of the given optical fiber.

**ANNA UNIVERSITY: CHENNAI – 600 025**  
**B.E./B.Tech. DEGREE EXAMINATIONS, MAY/JUNE - 2013**  
**Regulations - 2008**  
**Second Semester**  
**(Common to All Branches)**  
**GS2165 – PHYSICS LABORATORY**

**Date:**

**Time: 2 Hours**

**Maximum Marks: 50**

1. Determine the Young's modulus of the material of the given wooden scale by non-uniform bending.
2. Determine the band gap energy of a semiconductor by measuring the reverse saturation current at different temperatures.
3. Find the co-efficient of viscosity of the given liquid by Poiseuilles flow method. (Radius of the capillary tube should be given)
4. Determine the rigidity modulus of the material of a given wire using torsion pendulum. (Make measurement for one length of the wire.)
5. Determine the dispersive power of the given prism. (Angle of the prism should be given)
6. Determine (i) the wavelength of the laser light using grating ( $N= 100$  lines/mm) and (ii) the Numerical Aperture of the given optical fiber.
7. Determine the coefficient of thermal conductivity of a bad conductor using Lee's disc apparatus. Specific heat of the material of the given disc =  $370 \text{ Jkg}^{-1}\text{K}^{-1}$ .
8. Determine (i) the velocity of ultrasonic waves in the given liquid and (ii) the compressibility of the given liquid using ultrasonic interferometer.

9. Form interference fringes with the help of two optically plane glass plates, wire and sodium vapour lamp ( $\lambda = 589.3\text{nm}$ ). Record the readings for at least four sets of fringes difference. Determine the width of one fringe and hence calculate the thickness of the given wire.
10. Determine (i) the average size of the particles of a given powder using laser light of  $\lambda = 650\text{ nm}$  and (ii) the Numerical Aperture of the given optical fibre.
11. Determine (i) the wavelength of the given laser light and (ii) the angle of divergence.
12. Assuming the wavelength of Green as  $\lambda = 546.1\text{nm}$ , standardize the given grating i.e find the number of lines per meter in the grating and then determine the wavelength of the prominent spectral lines of mercury spectrum. (First Order Violet, Blue, Yellow – I, Yellow – II, Extreme Red

#### ALLOTMENT OF MARKS

HEADING	MAXIMUM MARKS	MARKS OBTAINED
FORMULAE	10	
CIRCUIT & DIAGRAM	10	
OBSERVATION	15	
CALCULATION	10	
RESULT	05	
TOTAL	50	

INTERNAL EXAMINER

EXTERNAL EXAMINER



**ANNA UNIVERSITY: CHENNAI – 600 025**

**B.E./B.Tech. DEGREE EXAMINATIONS, MAY/JUNE - 2013**

**Regulations - 2008**

**Second Semester**

**Date:**

**(Common to All Branches)**

**GS2165 PHYSICS LABORATORY**

**Time: 2 Hours**

**Maximum Marks: 50**

1. Find out the diameter of the given wire by forming an Air wedge. (Wavelength of sodium light =  $589.3nm$ )
2. Estimate the velocity of ultrasonic wave in the given liquid and also find compressibility of the liquid using ultrasonic interferometer.
3. Find out the number of lines drawn in one metre length of the given grating by keeping it in normal incidence position in a spectrometer and using the wavelength of mercury green as  $546.1nm$ . Hence, find the wave length of any three lines of mercury spectrum. (Use first order diffraction lines only)
4. Determine the Young's modulus of elasticity of the material of a given beam by non- uniform bending method. Readings should be taken at least for 6 loads.
5. Estimate the coefficient of viscosity of a given liquid by Poiseuille's flow method.
6. Determine (i) the period of oscillation of a given Torsional pendulum for a fixed length and (ii) the moment of inertia of the disc and rigidity modulus of the wire. Compare them with that theoretical values.
7. Determine the refractive index of the material of the prism for blue, green, yellow 1 & 2 and extreme red, and calculate the dispersive power of the same for blue & red, blue & green and yellow 1 & 2.
8. Determine (i) the wave length of the laser light using grating ( $N= 100$  lines/mm) and (ii) the Numerical Aperture of the given optical fibre.
9. Determine (i) the wavelength of the given laser light and (ii) the angle of divergence.
10. Determine the band gap energy of a semiconductor by measuring the reverse saturation current at different temperatures.

**ALLOTMENT OF MARKS**

<b>HEADING</b>	<b>MAXIMUM MARKS</b>	<b>MARKS OBTAINED</b>
<b>FORMULAE</b>	<b>10</b>	
<b>CIRCUIT &amp; DIAGRAM</b>	<b>10</b>	
<b>OBSERVATION</b>	<b>15</b>	
<b>CALCULATION</b>	<b>10</b>	
<b>RESULT</b>	<b>05</b>	
<b>TOTAL</b>	<b>50</b>	

**INTERNAL EXAMINER****EXTERNAL EXAMINER**

