

VALLIAMMAI ENGINEERING COLLEGE
SRM NAGAR, KATTANKULATHUR-603203
Department of Mechanical Engineering
SUBJECT: GE6152 ENGINEERING GRAPHICS
QUESTION BANK

UNIT 1(20 marks)

1. Infer the Construction of a hyperbola when the distance between the focus and directrix is 45 mm and eccentricity is $5/4$. Also draw the tangent and normal to any point on the curve. (BT4)
2. Infer the Construction of an ellipse when the distance between the focus and directrix is 35 mm and eccentricity is $3/4$. Also draw the tangent and normal to any point on the curve. (BT4)
3. Infer the Construction of a parabola when the distance between the focus and directrix is 30mm. Also draw the tangent and normal to any point on the curve. (BT4)
4. Infer the Construction of a cycloid given the radius of the generating circle is 30mm. also draw a tangent and normal at any point on the cycloid. (BT4)
5. Infer the Construction of a cycloid for one and half revolutions when the radius of the generating circle is 25mm. (BT4)
6. Develop an epicycloid of a circle 50 mm diameter which rolls outside of another circle of 100 mm diameter for one revolution. Draw tangent and normal to any point on the curve. (BT6)
7. Develop the hypocycloid of a circle of 50mm diameter which rolls inside another circle of 100 mm diameter for one revolution. Draw tangent and normal at any point on the curve. (BT6)
8. A coir is unwound from a drum of 30 mm diameter. Draw the locus of the free end of the coir for unwinding through an angle of 360° . Also draw normal and tangent at any point on the curve. (BT1)
9. Develop the Involute of a circle of radius 20mm. Also draw the tangent and normal at any point on the curve (BT6)
10. Develop the Involute of a square of side 25mm. Also draw the tangent and normal at any point on the curve. (BT6)
11. Draw the three orthographic views for the following fig. (BT1)

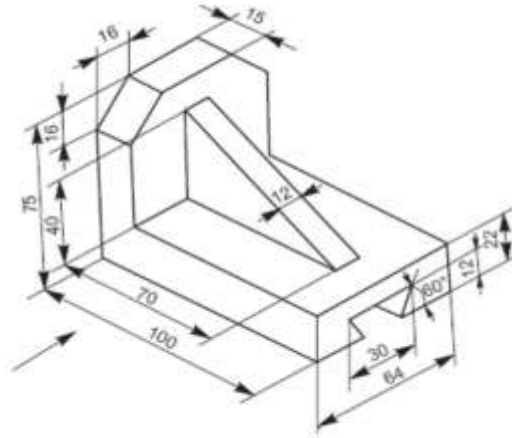

12. Draw the three orthographic views for the following fig.

(BT1)

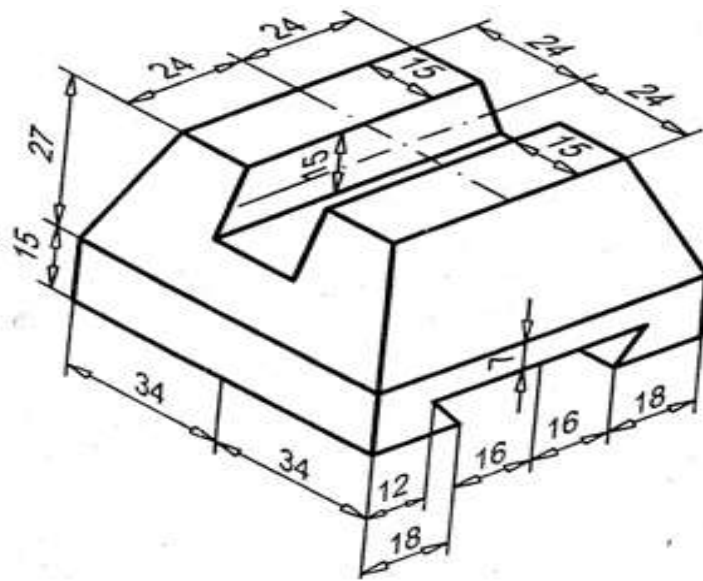

13. Draw the three orthographic views for the following fig.

(BT1)

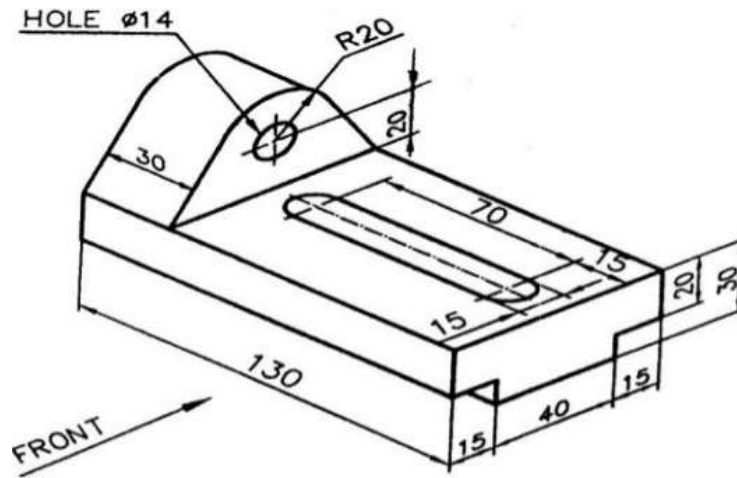

14. Draw the three orthographic views for the following fig.

(BT1)

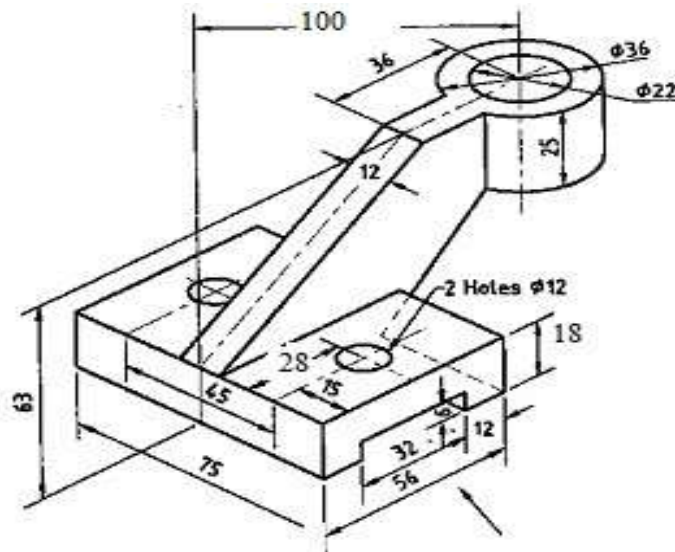

3. One end of a line AB is 5mm above HP and 15mm in front of VP. Its elevation and plan measures 50mm and 65mm respectively. The elevation is inclined at 50° . Draw the projections and find true length and true inclinations. (BT1)
4. The plan of a line AB is 80mm long and makes 35° with XY. Its elevation makes 45° with XY and the line intersects XY at A. Identify and find its true length and inclinations to HP and VP. Also mark the traces. (BT1)
5. The top view of a line is 65mm long and inclined to XY at 30° . One end is 20mm above HP and 10mm in front of VP. The other end is 60mm above HP and is in front of VP. Identify and find the true length of the line, its inclination with HP and VP. Also mark the traces. (BT1)
6. A point P is 45mm above HP and 25mm in front of VP. Another point Q is 25mm above HP and 55mm in front of VP. The top view of the line PQ is inclined at 40° to XY line. Draw the projections of the line. Identify and find the true length and true inclinations of the line with HP and VP. (BT1)
7. A line AB 75mm long has its end A in both HP and VP. The line is inclined 45° to HP and 30° to VP. Draw the projections. (BT1)
8. A line measuring 75mm long has one of its ends 50mm in front of VP and 20mm above HP. The other end is 15mm in front of VP and above HP. The top view of the line measures 50mm. Draw the projections and find its true inclinations. (BT1)
9. The midpoint of a line AB is 35mm above HP and 45mm in front of VP. The top view and front view of the line measures 80mm and 70mm respectively. The end A is 10mm in front of VP and the end B is nearer to HP. Draw the projections and find its true length and true inclinations. (BT1)
10. The mid point of a straight line AB 90mm long is 60mm above HP and 50mm in front of VP. It is inclined 45° to VP and 30° to HP. Draw the projections. (BT1)
11. A regular hexagon of side 40mm is resting on one of its corners on HP and the surface inclined 45° to HP. Draw the projections when the diagonal through the corner resting on HP makes an angle of 60° with VP. (BT1)
12. A pentagonal lamina of side 30mm rests on the ground with one of its sides inclined at 30° to VP while the surface of the lamina is inclined at 45° to HP. Draw the projections of the lamina. (BT1)
13. A rectangular plate of size 60mm x 30mm has one of its shorter edges in VP and inclined at 40° to HP. Draw its top view if its front view is a square of side 30mm. (BT1)
14. Draw the projections of a square plane of side 35mm rests on the ground on one of its corners with a diagonal containing that corner is inclined 40° to HP and 50° to VP. (BT1)
15. A circular plate of negligible thickness and 50mm diameter is vertical and inclined at 45° to VP. Draw its projections when the centre of the circular lamina is 40mm above HP and 60mm in front of VP. (BT1)

UNIT 3(20 marks)

1. A pentagonal prism of base side 35mm, axis height 60mm is resting on HP on one of its base edges with its axis inclined at 45° to HP and parallel to VP. Draw the projections of the prism. (BT1)
2. A hexagonal prism of base side 30mm, axis height 50mm is resting on HP on one of its base corners with its base inclined at 35° to HP and parallel to VP. Draw the projections of the prism. (BT1)
3. A square pyramid of base side 30mm, axis height 60mm is resting on HP on one of its base corners with its axis inclined at 50° to HP and parallel to VP. Draw its projections when the base sides containing the resting corners are equally inclined to HP. (BT1)
4. A pentagonal pyramid of base side 30mm, axis height 60mm is resting on HP on one of its base corners with its axis inclined at 50° to HP and parallel to VP. Draw the projections of the pyramid. (BT1)
5. A hexagonal pyramid of base side 30mm, axis height 60mm is resting on HP on one of its base corners with its axis inclined at 40° to HP and parallel to VP. Draw its projections when the base sides containing the resting corners are equally inclined to HP. (BT1)
6. A pentagonal pyramid of base side 30mm and axis height 55mm is resting on HP on one of its base edges with the face containing the resting edge perpendicular to both HP and VP. Draw its projections. (BT1)
7. A hexagonal pyramid of base side 30mm and axis height 50mm is resting on HP on one of its base corners with its axis parallel to VP. Draw its projections when the slant edge containing the resting corner is vertical. (BT1)
8. A square pyramid of base side 40mm and axis height 50mm is resting on HP on one of its base corners with its axis parallel to VP. Draw its projections when the slant edge containing the resting corner is vertical. (BT1)
9. A pentagonal prism of base 30mm and axis length 60mm is resting on HP on one of its rectangular faces with its axis inclined 45° to VP. Draw its projections. (BT1)
10. A hexagonal pyramid of base side 35mm and axis height 65mm is resting on HP on one of its triangular faces with its axis parallel to VP. Draw its projections. (BT1)
11. A cone of base diameter 50mm and axis height 65mm is resting on HP on one of its generators with its axis parallel to VP. Draw its projections. (BT1)
12. A cylinder of base diameter 50mm and axis height 65mm is resting on HP on one of its generators with its axis inclined at 50° to VP. Draw its projections. (BT1)
13. A cylinder of base diameter 50mm and axis height 65mm is resting on HP on a point on the circumference of the base with its axis inclined at 50° to HP and parallel to VP. Draw its projections. (BT1)

14. A pentagonal pyramid of base side 30mm and axis length 60mm is suspended by means of a string from one of its base corners with its axis parallel to VP. Draw its projections. (BT1)
15. A square pyramid of base side 30mm and axis length 60mm is suspended by means of a string from one of its base corners with its axis parallel to VP. Draw its projections. (BT1)

UNIT 4(20 marks)

1. A hexagonal prism of base 30mm and axis 60mm rests on its base on HP with its axis perpendicular to HP and one of the base edge parallel to VP. The solid is cut by a plane which is perpendicular to VP, inclined at 40° to HP and bisecting the axis of the prism. Draw the front view, sectional top view and true shape of the section. (BT1)
2. A square pyramid has a base side of 40mm and altitude 80mm. It rests with its base on HP such that one side of the base is inclined at 30° to VP. The pyramid is cut by a plane which bisects the axis and is inclined at 45° to HP. Draw the front view, sectional top view and true shape of the section. (BT1)
3. A cylinder of base diameter 50mm and height 65mm rests on its base on HP. It is cut by a plane perpendicular to VP and inclined at 30° to HP and meets the axis at a distance 30mm from the base. Draw the front view, sectional top view and true shape of the section. (BT1)
4. A cone of base diameter 40mm and altitude 50mm rests on its base on the HP. It is cut by a plane inclined at 45° to HP and passes through a point on axis which is 20mm above HP. Draw the front view, sectional top view and true shape of the section. (BT1)
5. A hexagonal pyramid of base 35mm and axis 70mm is resting on HP on its base with two sides of base perpendicular to VP. It is cut by a plane inclined at 45° to VP, perpendicular to HP and 10mm away from the axis. Draw its top view, sectional front view and true shape of the section. (BT1)
6. A hexagonal prism, side of base 45mm and axis 75mm long, rests with its base on HP such that one of its rectangular faces is parallel to VP. A sectional plane perpendicular to HP and parallel to VP cuts the prism at a distance of 15mm from the axis. Draw its top view and sectional front view. (BT1)
7. A cone of base diameter 50mm and axis length 60mm is resting on HP on its base. It is cut by a plane inclined at 40° to VP and perpendicular to HP that cuts the cone at a distance of 10mm from the axis and in front of it. Draw its top view, sectional front view and true shape of the section. (BT1)
8. A hexagonal pyramid of base side 30mm and axis height 60mm is resting on HP on its base with a base edge parallel to VP. It is cut by a plane perpendicular to VP,

- inclined 70° to HP and passing through a point in its axis at a distance of 20mm from the base. Draw the sectional top view and true shape of the section. (BT1)
9. A hexagonal prism of base 35mm side and axis 65mm long is resting on its base on HP with a base edge parallel to VP. It is cut by a plane perpendicular to HP, inclined 50° to VP and 15mm away from the axis of the prism. Draw the top view and sectional front view of the prism. Also draw the true shape of the section. (BT1)
 10. A hexagonal pyramid of base side 30mm and axis height 60mm is resting on its base on HP with two of the base edges parallel to VP. It is cut by a plane perpendicular to VP, inclined 30° to HP and bisects the axis of the pyramid. Draw the development of the lateral surfaces of the lower portion of the pyramid. (BT1)
 11. A cylinder of base diameter 40mm and height 65mm rests on its base on HP. It is cut by a plane perpendicular to VP and inclined at 30° to HP and meets the axis at a distance 30mm from the base. Draw the development of the lateral surface of the cylinder. (BT1)
 12. A hexagonal prism of base side 30mm and axis 60mm is resting on HP on one of its bases with two of the vertical faces perpendicular to VP. It is cut by a plane inclined at 50° to HP and perpendicular to VP passing the axis at a distance of 35mm from the top surface. Draw the development of the remaining portion of the prism. (BT1)
 13. A square pyramid has a base side of 40mm and altitude 80mm. It rests with its base on HP such that one side of the base is inclined at 30° to VP. The pyramid is cut by a plane which bisects the axis and is inclined at 45° to HP. Draw the development of the remaining portion of the pyramid. (BT1)
 14. A pentagonal pyramid has a base side of 30mm and axis height of 70mm. It rests with its base on HP such that one of the base edges perpendicular to VP. The pyramid is cut by a plane which bisects the axis and is inclined at 30° to HP. Draw the development of the remaining portion of the pyramid. (BT1)
 15. A cone of base diameter 40mm and altitude 60mm rests on its base on the HP. It is cut by a plane inclined at 40° to HP and passes through a point on axis which is 40mm above HP. Draw the development of the lateral surface of the lower portion of the cone. (BT1)

UNIT 5(20 marks)

1. A hexagonal pyramid of base side 30mm and height 60mm rests on its base on HP with two of its base edges perpendicular to VP. It is cut by a plane perpendicular to VP and inclined at 25° to HP, meeting the axis at a point 25mm above the base of the pyramid. Draw the isometric projection of the truncated pyramid. (BT1)
2. A cylinder of base diameter 40mm and height 60mm rests on its base on HP. It is cut by a plane perpendicular to VP and inclined at 45° to HP. The cutting plane meets the axis at a distance of 15mm from the top surface. Draw the isometric view of the truncated cylinder. (BT1)

3. A cylinder of base diameter 50mm and height 60mm rests on its base on HP. It is cut by a plane perpendicular to VP and inclined at 50° to HP. The cutting plane meets the axis at a distance of 15mm from the top surface. Draw the isometric projection of the truncated cylinder. (BT1)
4. A hexagonal prism of base side 30mm and axis 60mm is resting on HP on one of its bases with two of the vertical faces perpendicular to VP. It is cut by a plane inclined at 50° to HP and perpendicular to VP passing the axis at a distance of 12mm from the top surface. Draw the isometric projection of the truncated prism. (BT1)
5. A pentagonal pyramid of base 30mm and height 65mm stands with its base on HP. An edge of the base is parallel to VP and nearer to it. A horizontal section plane cuts the pyramid and passes through a point on the axis at a distance of 25mm from the apex. Draw the isometric view of the frustum of the pyramid. (BT1)
6. A cone of base diameter 50mm and height 70mm stands on HP with its base. It is cut by a cutting plane perpendicular to VP and inclined at 30° to HP cutting the axis of the cone at a height of 40mm from its base. Draw the isometric view of the remaining part of the cone. (BT1)
7. A pentagonal prism of base side 30mm, axis 60mm is resting on its base on HP with one of its base edges perpendicular to VP. It is cut by a plane perpendicular to VP, inclined 55° to HP and cut the axis at a distance of 35mm from the base. Draw the isometric projection of the truncated prism. (BT1)
8. A sphere of radius 18mm is placed centrally over a hexagonal slab of side 24mm and thickness 25mm. Draw the isometric view of the combined solid. (BT1)
9. The frustum of a pentagonal pyramid with base side 30mm and top surface of 15mm side has a height of 40mm. draw its isometric view. (BT1)
10. A rectangular pyramid of sides 30mm x 20mm and height 35mm rests with its base on ground such that one of the longer edges is parallel to picture plane and 30mm behind it. The station point is 50mm in front of the picture plane, 30mm to the left of the axis of the pyramid and 50mm above the ground. Draw the perspective view of the pyramid. (BT1)
11. A square pyramid of base side 50mm and height 75mm rests with its base on ground such that the nearest edge of the base is parallel to picture plane and 30mm behind it. The station point is 70mm in front of the picture plane, 60mm to the right of the axis of the pyramid and 50mm above the ground. Draw the perspective view of the pyramid. (BT1)
12. A cube of 35mm edge lies with a face on the ground and an edge on the picture plane. All the vertical faces are equally inclined to picture plane. The station point is 80mm in front of the PP and 60mm above the ground. The edge of the cube in contact with the picture plane is situated 10mm to the right of the station point. Draw the perspective projection of the cube. (BT1)
13. A cube of 30mm edge lies with a face on the ground and two vertical faces perpendicular to picture plane. The front face of the cube is 10mm in front of picture

- plane. The station point is 60mm in front of the PP and 60mm above the ground. The nearest edge of the cube is 20mm to the right of the station point. Draw the perspective projection of the cube. (BT1)
14. A frustum of a square pyramid of base edge 30mm and top edge 20mm. The height of the frustum is 35mm. It rests on its base on the ground with the base edges equally inclined to picture plane. The axis of the frustum is 30mm to the right of the station point. The station point is 55mm in front of PP and 50mm above GP. The nearest base corner is 10mm behind picture plane. Draw the perspective projection of the frustum. (BT1)
15. A square pyramid of base 30mm, axis height 45mm rests with its base on GP. One of the base edges is parallel to PP and 20mm behind it. The station point S is 60mm above ground plane, 70mm in front of picture plane and lies in the central plane which is 40mm to the right of the axis of the pyramid. Draw the perspective projection of the square pyramid. (BT1)